

ITTA-3013-C ITTA-3013-L

10Gb/s integrated tunable transmitter assembly with MZ modulator

Integrated Tunable Transmitter Assembly

Features

- Wide tuning range using highly reliable DFB laser arrays
- Excellent wavelength stability with no possibility of mode hop
- Modulated output power of 3.5 dBm
- Zero Chirp (up to 1200ps/nm applications)
- Co-Planar / dual GPPO differential drive <2.7V

Applications

- 1550 nm widely tunable DFB source for DWDM systems
- Small form factor full band tunable 10Gb/s transponders

Benefits

- Size
- Eliminates PM fiber, splicing and reduces fiber handling
- Differential drive enables use of lower cost EML drivers
- Ease of use

*The **ITTA-3013-C** and **ITTA-3013-L** are a new generation of compact C- and L-band widely tunable 10Gb/s modulated sources. They integrate Santur's widely tunable DFB array technology with a semiconductor Mach-Zehnder modulator. The integrated assembly provides for a highly efficient, small form factor assembly that can replace a CW ITLA and LiNbO₃ modulator in many applications.*

*Ideally suited for use in a wide variety of DWDM systems, the Santur **ITTA-3013-C/L** provides the best combination of performance features available. They offer a unique combination of modulated optical power, wide tunability, and excellent modulation characteristics. The module is a combination of the TL3000 tunable laser, with integrated wavelength locker, and a chirped 10Gb/s dual drive semiconductor Mach-Zehnder modulator.*

Excellent performance characteristics, reliability, ease of manufacture, and economies of scale derived from Santur's exclusive, proven design, differentiate this product from others in the industry.



Specifications:

Symbol	Parameter	Conditions	ITTA-3013-C			ITLA-3013-L			Unit
			Min	Typ	Max	Min	Typ	Max	
Standard operating requirements									
	Bit Rate	-	11.3			11.3			Gb/s
	Optical frequency		191.5		196.1	187.6		190.9	THz
	Optical frequency accuracy (EOL)		-2.5		2.5	-2.5		2.5	GHz
	Optical frequency accuracy (BOL)		-1.5		1.5	-1.5		1.5	GHz
T _{switch}	Wavelength switching time			3	30		3	30	s
P-out	Modulated output power		2.6	3.5	4.2	2.6	3.5	4.2	dBm
	Linewidth			2	10		2	10	MHz
SMSR	Sidemode suppression ratio		40			40			dB
OSNR	Optical signal to noise ratio		45			45			dB/0.1nm
RIN	Relative intensity noise	200MHz – 8GHz	-135			-135			dB/Hz
	Linewidth range for SBS suppression		500			500		1000	MHz
Modulator specifications									
V _π	DataN arm V _π			2.7			2.7		V
V-bias	MZ Bias		-5		0	-5		0	V
V-biasN	MZ bias N		-5		0	-5		0	V
	DC extinction ratio		25			25			dB
E _r	AC extinction ratio		10			10			dB
S21	3dB frequency	-	11			11			dB
	S21-ripple	2-9GHz	-0.5		0.5	-0.5		0.5	dB
S11	Return loss of RF port	50 MHz to 8 GHz			-10			-10	dB
S11	Return loss of RF port	8 to 12 GHz			-5			-5	dB
	Dispersion penalty	At 1200ps/nm, dual drive, 10.7Gb/s			1			1	dB
	Rf Input	Dual GPPO							
Electrical Specifications									
V _{cc}	Positive supply voltage	-	3.15	3.3	3.45	3.15	3.3	3.45	V
V _{ee}	Negative supply voltage		-5.45	-5.2	-4.94	-5.45	-5.2	-4.94	V
I _{cc}	Positive supply current	Peak	-	-	1.4	-	-	1.4	A
I _{ee}	Negative supply current	Peak	1.0			1.0			A
P _d	Total power dissipation, steady-state	T _{case} = 75°C	-	1.5	3.5	-	1.5	3.5	W
		T _{case} = 75°C	-	3	6.5	-	3	6.5	W
	SBS modulation	Internal – triangle wave	10		50	10		50	KHz
Fiber Pigtail									
	Fiber type	SMF-28	-	-	-	-	-	-	
L	Length of pigtail	-	1.0	-	-	1.0	-	-	m
R	Bending radius	-	35	-	-	35	-	-	mm
F	Tensile strength (fiber to case)	-	-	-	5	-	-	5	N
	Optical connector	FC/UPC R-Type (narrow key)	-	-	-	-	-	-	
Absolute Maximum Ratings									
T _{op}	Case operating temperature*	-	-5	-	75	-5	-	75	°C
T _{stg}	Storage temperature range*	-	-40	-	85	-40	-	85	°C
	Signal pin voltage		-0.3		3.6	-0.3		3.6	V

*non-condensing

Custom OEM specifications possible. Contact Santur for your needs.

Performance Characteristics:

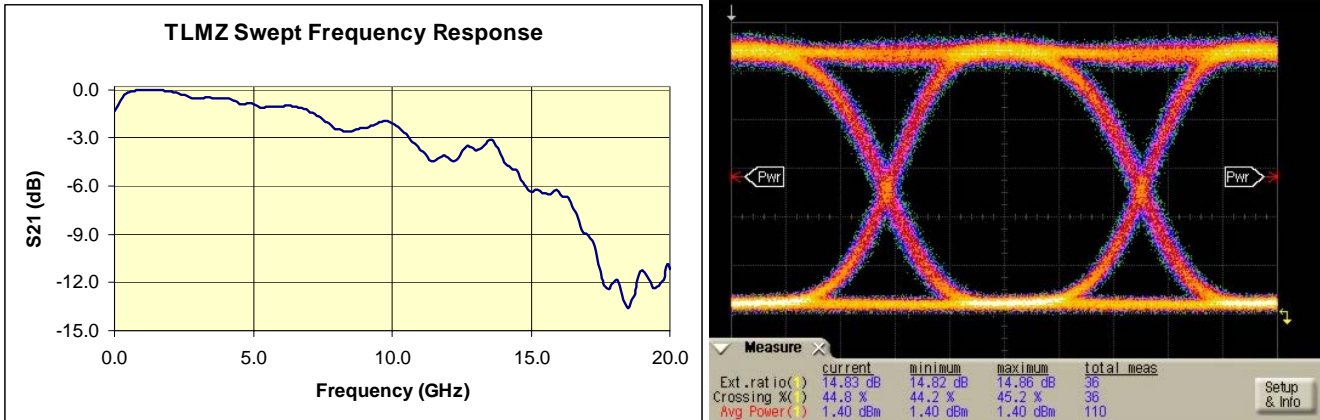

Mechanical Outline:

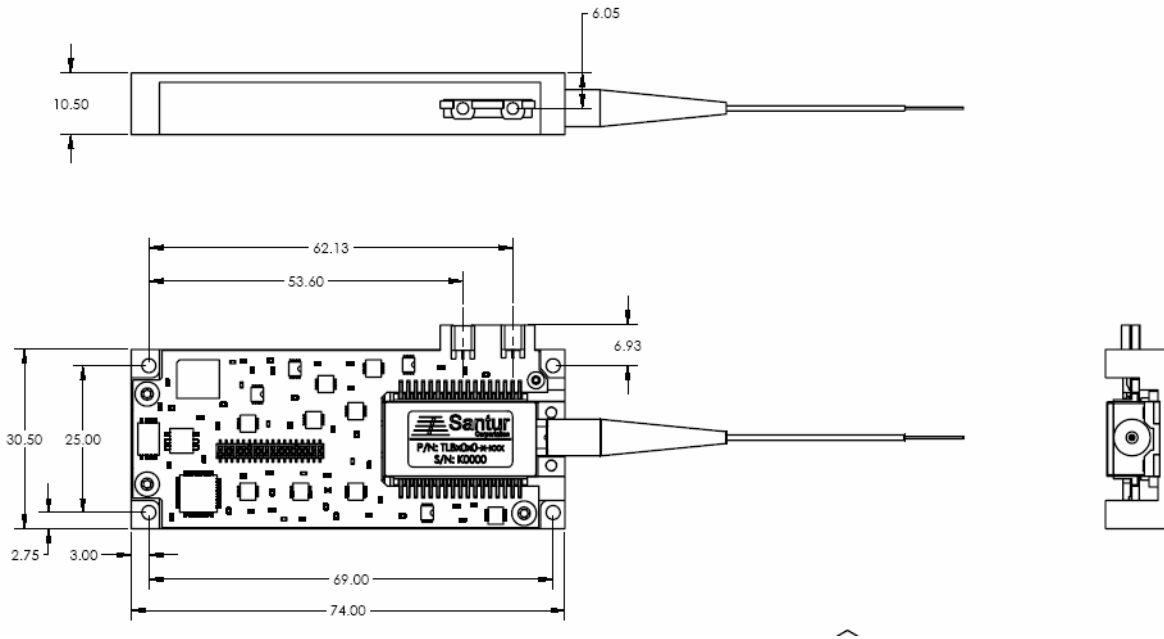

Schematic measurements are in millimeters.

Connector is Samtec CLM-118-02 style.

Connection to customer system is via mating Samtec FTM-118-03 or custom flex jumper.

Connector Pin Assignment

Pin Name	Pin #	Pin #	Pin Name
Manufact.	1	2	MZ Bias 1
Manufact.	3	4	MZ PD 1
GND	5	6	MZ PD 2
Manufact.	7	8	Manufact.
Manufact.	9	10	MZ Bias 2
Manufact.	11	12	MZ MPD
Manufact.	13	14	Manufact.
Manufact.	15	16	Manufact.
Manufact.	17	18	Manufact.
Manufact.	19	20	Manufact.
I2C Clk	21	22	Manufact.
I2C Dat	23	24	-5.2V
OIF DIS_N	25	26	-5.2V
OIF SRQ_N	27	28	GND
OIF MS_N	29	30	GND
OIF TXD	31	32	GND
OIF RXD	33	34	+3.3V
OIF RES_N	35	36	+3.3V

Note: Manufact. pins should be left as no-connects.

Additional information on the communication interface and command set can be found in OIF document oif2005.128.04. See www.oiforum.com.

International Sales Contacts

Benelux and Nordics
Laser 2000 Benelux S.A.
Rue du Moulin 18
5650 Fraire, Belgium
Tel: +32 (0) 71 610 640
Fax: +32 (0) 71 610 649
sales@laser2000.be

Germany
Laser 2000 GmbH
Argelsrieder Feld 14
82234 Wessling
Tel: +49 (0) 8153 405-0
Fax: +49 (0) 8153 405-33
contact@laser2000.de

United Kingdom
Laser 2000 (UK) Ltd
Britannia House
Denford Road
Ringstead, Northants NN14 4DF
Tel: +44 (0) 1933 461 666
Fax: +44 (0) 1933 461 699
sales@laser2000.co.uk

China
LuY Broadband Tech. Co.
Room 824 Hua Tong Plaza
No. 19A West Rd. of Che Gong Zhuang
Haidan Dist, Beijing 100044
Tel: +86 (8610) 68700016
Fax: +86 (8610) 6845151
william.lu@luy-tech.com

Israel
Bitel Technologies Ltd.
P.O. Box 94, Yehud
Tel: +972-3-632 2655
Fax: +972-3-632 2279
info@bitel.co.il

France
Laser 2000 S.A.
Park d'Affaires
3, Rue de la Plaine
78860 Saint-Nom la Bretèche
Tel: +33 (0) 1 30 80 00 60
Fax: +33 (0) 1 30 80 00 40
contact@laser2000.fr

Japan
Marubun Corporation
Components Dept.
Marubun Daiya Bldg., 8-1
Nihonbashi Odeamacho
Chuo-ku, Tokyo 103-8577
Tel: (03) 3639-9881
Fax: (03) 5644-7627
motizuki@marubun.co.jp



This is an OEM product that does not comply with the requirements of 21 CFR Subchapter 1 as applicable. It is the responsibility of the user to report the end product and to certify that it meets all applicable requirements.



DANGER: Fiber output is >10 mWatt at 1555 nm.
Do not look into fiber end.

Santur Corporation
40931 Encyclopedia Circle
Fremont, CA 94538
Phone: (510) 656-7130
Fax (510) 656-7563
www.santurcorp.com
1-866-TUNABLE

© 2005 Santur Corporation. The Santur Corporation logo is a trademark of Santur Corporation. The ITLA-3020-C/L product is registered with the U.S. Office of Patents and Trademarks. All rights reserved. Santur Corporation reserves the right to make changes to the product(s) or information contained herein without notice. No liability is assumed as a result of their use of application.